

Installation and Operating Instructions

Thank you very much for choosing a high quality product from motogadget. All of our products are designed and manufactured in Germany. By choosing a motogadget product, you help to ensure that jobs stay in Germany.

Please read the following instructions carefully and follow them when installing your turn signals.

THE MAXIMUM ELECTRICAL PUSH-BUTTON LOAD RATING IS 0.05 A OR 0.2 W RESPECTIVELY. UNDER NO CIRCUMSTANCES MAY THE APPLIANCES BE SWITCHED DIRECTLY USING THE PUSH-BUTTONS. THE INTENDED USE OF THE PUSH-BUTTONS IS THE COMBINATION WITH ELECTRONICAL PUSH-BUTTON CONTROLS ONLY (E.G. M-UNIT, M-RELAY+). IT IS POSSIBLE TO USE THE PUSH-BUTTONS AS MENU BUTTONS FOR MOTOGADGET INSTRUMENTS DIRECTLY.

THE CASING MUST NOT BE MODIFIED OR OPENED. IN CASE OF MECHANICAL MODIFICATION, ALL WARRANTY CLAIMS WILL BECOME VOID. IN CASE OF UNINTENDED USE, ALL WARRANTY CLAIMS WILL BECOME VOID. MOTOGADGET WILL NOT BE LIABLE FOR ANY DIRECT OR INDIRECT DAMAGE OR CONSEQUENTIAL DAMAGE OF ANY KIND RESULTING FROM THE USE, INSTALLATION OR CONNECTION OF THE DEVICE OR OTHER DELIVERED EQUIPMENT. THIS EXCLUSION OF LIABILITY APPLIES TO, INCLUDING BUT NOT LIMITED TO, PERSONAL, MATERIAL AND FINANCIAL DAMAGES.

Mechanical Installation

First, the handles, turn signals, and brake and clutch instruments are mounted at their final positions on the handlebar.

Unscrew the m-switch mini and hold the push-button part in the desired position on the handlebar. Take a pen and mark the position of the cable hole on the handlebar precisely. The cable hole will determine the future position of the push-button assembly. Make sure to set the cable hole marking very precisely - it is not possible to correct the position after the cable hole has been drilled.

Drill one cable hole each of 5mm diameter on the left-hand and right-hand side of the handlebar. We recommend to drill a 6mm hole on the bottom of the handlebar center position for both cables to exit. Make sure to remove all burrs on the insides and outsides of the holes. Existing burrs can damage the cable insulation and cause short circuits leading to irreparable damage of the push-button assembly.

Now place the push-button half of the m-switch mini on the handlebar and route the cable through the hole to the handlebar center and then out of the 6mm hole in the handlebar.

As a final step, mount the rear side of the m-switch mini. This part is designed asymmetrically to produce a clamping gap. During installation, make sure the clamping gap is oriented to the bottom of the handlebar. The maximum mounting torque of both clamping screws is 2 Nm.

Electrical Installation

Two of the three push-buttons are internally connected; one push-button can be allocated as desired. For use with the m-unit, connect the black cable and red cable to the ground terminals and connect the white, yellow and green cables to the desired input terminals on the m-unit.

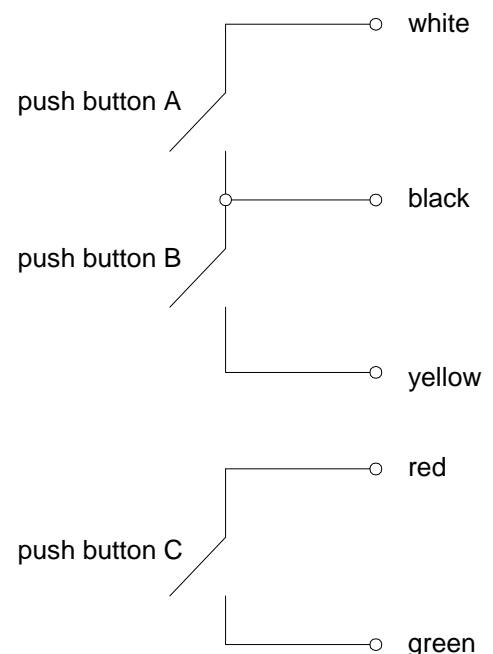

Your motogadget team wishes you a pleasant and safe ride, and lots of fun with your new m-switch mini.